

EPP-6

ELECTRONICALLY-CONTROLLED 6:1 RATIO PISTON PUMP

Valco Cincinnati's Model EPP-6 piston pump is automatically reversed by low-voltage, solid-state electronics. Most common pumps use an air-motor-driven, mechanical device to reverse the pump stroke. These reversing mechanisms can "hang-up" and stall the pump when operated at low air pressure or when cycling at slow speeds. In addition, mechanical reversing devices wear out, resulting in frequent downtime for maintenance and rebuilding.

The EPP-6 features an electronic reversing control that is extremely reliable and not affected by normal wear characteristics of mechanical devices. The pump simply cannot hang up or stall! When used for intermittent output applications the pump will stop, then immediately restart as the system requires.

The electronic reversing control enables the pump to operate at reduced air pressures without hanging up. This can offer significantly reduced air consumption. It also permits very slow cycling for applications where demand is low or when pumping viscous materials.



- Reliable, solid-state electronic reversing control
- Can be cycled very slowly or operated at reduced air pressure without stalling or hanging up
- Compact, lightweight construction
- Optional drum cover, pail lid and wall-mount kits

VALCO
CINCINNATI



Worldwide Sales Network

FAST, SIMPLE MAINTENANCE

Valco Cincinnati's piston pumps are engineered to keep downtime at a minimum. The unique, solid-state reversing control is far more reliable and less complex than the air-motor-driven mechanisms common to other piston pumps.

VERSATILE

The electronic reversing control opens the door to custom and specialized requirements that are not possible with conventional air-powered pumps. For example, the pump can interface with other controls or data systems to provide automatic usage readout, metered outputs and automatic level control.

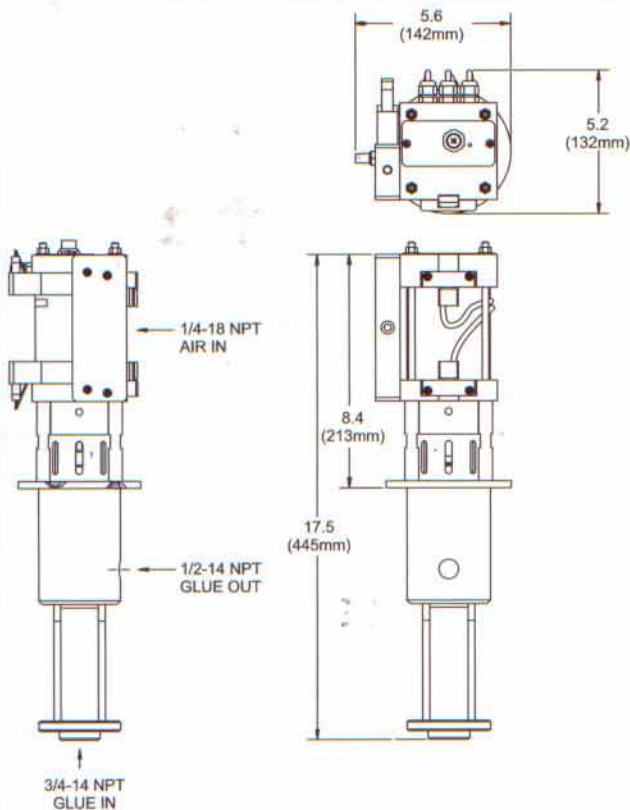

Pump ratio: 6:1
Minimum air pressure: 20 psi
Maximum air pressure: 100 psi

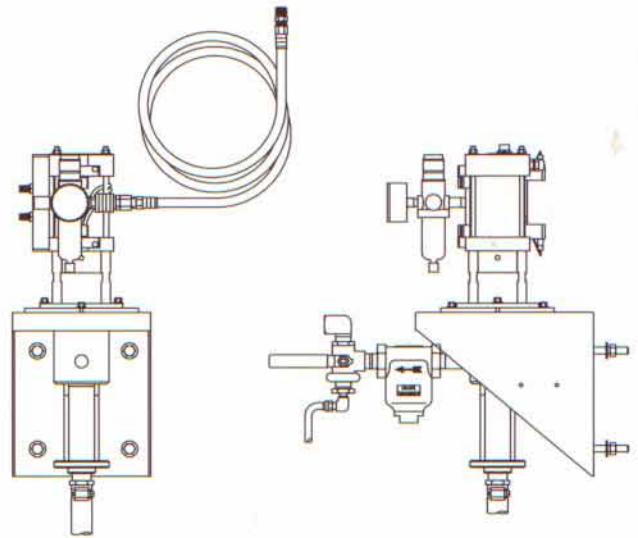

Shown with wall-mounted kit (above) and pail-mounted kit (below). Drum-mount kits are also available

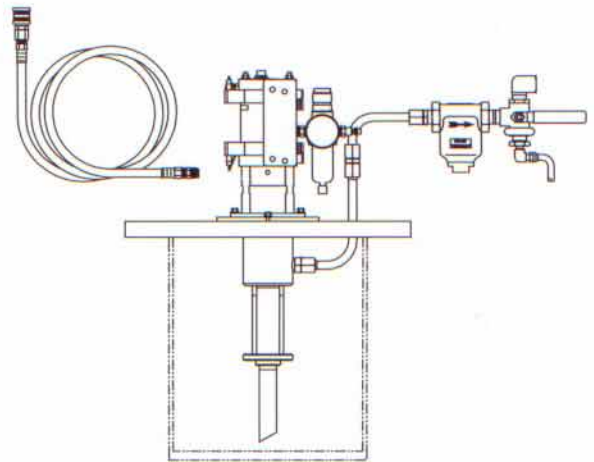

Contact Valco Cincinnati for all your pumping system needs. We can supply drum covers and mounting brackets to simplify your installation and we also offer pressure hoses, regulators, gauge and gauge protectors, filters, valves, an electronically-reversed 1:1 diaphragm pump, and electronic controls that adapt to meet many requirements.

SS007 (8-03)

Valco Cincinnati Inc.
411 Circle Freeway Drive
Cincinnati, OH 45246 USA
TEL: (1) 513-874-6550
FAX: (1) 513-874-3612

Valco Cincinnati Ltd.
Hortonwood 32
Telford, TF1 7YN, United Kingdom
TEL: (44) 1952-677911
FAX: (44) 1952-677945

Valco Cincinnati GmbH
Storkower Str.6
15749 Gallun, Germany
TEL: (49) 33764 870-0
FAX: (49) 33764 870-70

